

REV	DESCRIPTION	ECN #	CHG BY	DATE	APP'D
A	CONVERTED TO 3D	16375	EZR	06/04/19	TAS

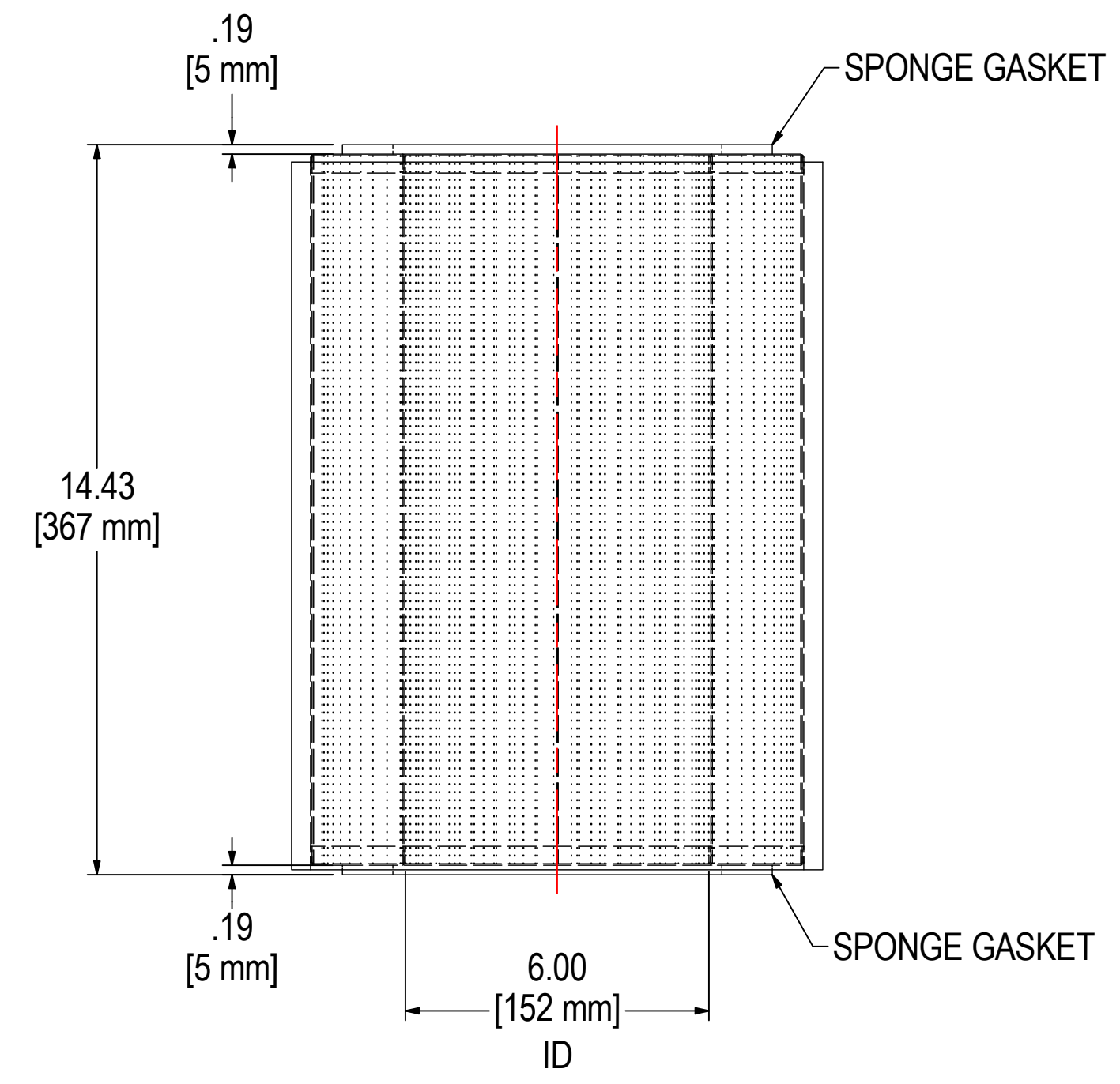
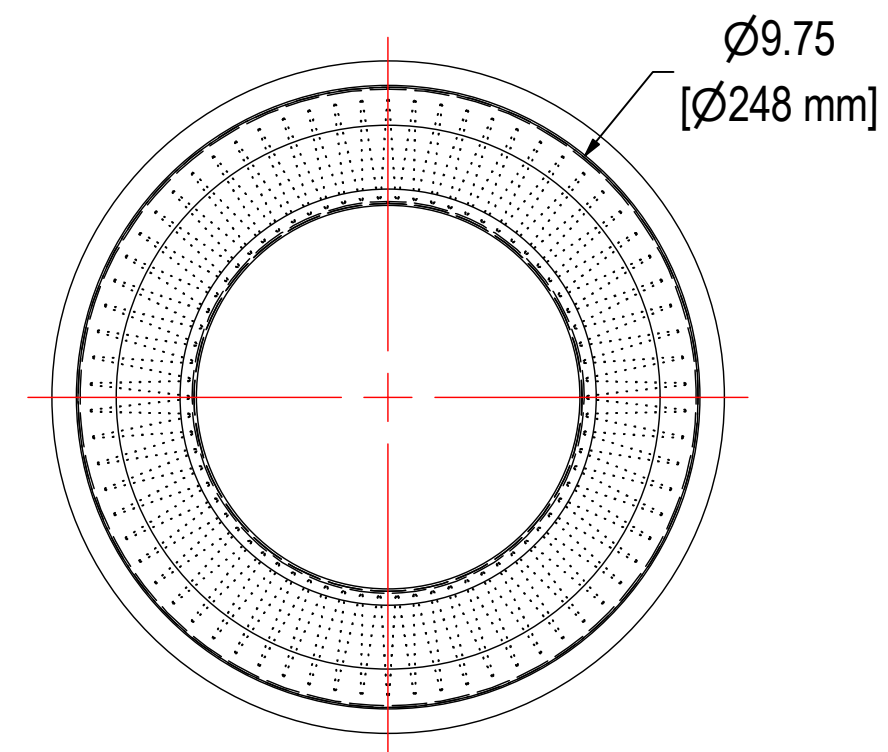

ELEMENT SPECS		
PART NUMBER	344P	
MATERIAL	Paper	
FLOW RATE	1100 CFM	1869 m ³ /hr
SURFACE AREA	57.0 ft ²	5.3 m ²
I.D.	6.00"	152mm
O.D.	9.75"	248mm
HEIGHT	14.50"	368mm

SOLBERG
Filtration • Separation • Silencing
630.773.1363 • www.solbergmfg.com

THE INFORMATION CONTAINED HEREIN IS CONFIDENTIAL AND THE PROPERTY OF SOLBERG MANUFACTURING INC. AND IT IS FURNISHED TO YOU WITH THE EXPRESS UNDERSTANDING THAT IT WILL NOT BE REPRODUCED, COPIED IN ANY MANNER, LOANED OR OTHERWISE TRANSFERRED TO OTHERS ENTIRELY OR IN PART, NOR USED FOR ANY PURPOSE OTHER THAN FOR WHICH IT WAS FURNISHED. IT WILL BE RETURNED UPON REQUEST TO SOLBERG MANUFACTURING INC. THE ABOVE RESTRICTION IS IN ADDITION TO, AND DOES NOT IN ANY WAY ALTER, ANY OTHER RESTRICTIONS WHICH MAY APPLY TO THE INFORMATION CONTAINED HEREIN.

TOLERANCES
DIMENSIONS ARE FOR REFERENCE ONLY. ALL DIMENSIONS ARE SUBJECT TO CHANGE UPON PRODUCTION.
UNLESS OTHERWISE SPECIFIED:
-DIMENSIONS ARE IN INCHES
-REF: APPROXIMATE DIMENSIONS, NO TOLERANCES APPLY
-FINISH: BREAK EDGES TO .005-.020 RADIUS/CHAMFER

MODEL NUMBER: 344P	SHEET: 1 OF 1	
DESCRIPTION: 344P, PAPER		
PROJECT: SD21334	DRAWN BY: EZR DATE: 4/27/2015	APPROVED BY: MJC DATE: 4/27/2015
		REV: A